

Technical data sheet



Product features

Cooking range electric 4x plate on open cabinet 400 V

Model	SAP Code	00012398
SPL 90/80 E	A group of articles - web	Stoves



- Device type: Electric unit
- Power consumption of the zone 1 [kW]: 3
- Power consumption of the zone 2 [kW]: 3
- Power consumption of the zone 3 [kW]: 3
- Power consumption of the zone 4 [kW]: 3
- Material: AISI 304 top plate, AISI 430 cladding

SAP Code	00012398	Number of zones	4
Net Width [mm]	800	Power consumption of the zone 1 [kW]	3
Net Depth [mm]	900	Power consumption of the zone 2 [kW]	3
Net Height [mm]	900	Power consumption of the zone 3 [kW]	3
Net Weight [kg]	107.00	Power consumption of the zone 4 [kW]	3
Power electric [kW]	10.000	Diameter of device [mm]	300
Loading	400 V / 3N - 50 Hz		

Technical data sheet



Technical drawing

Cooking range electric 4x plate on open cabinet 400 V

Model	SAP Code	00012398
SPL 90/80 E	A group of articles - web	Stoves

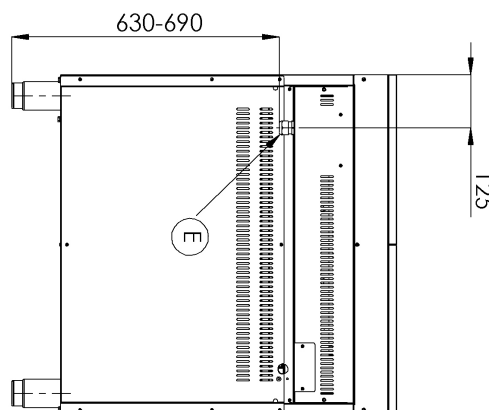
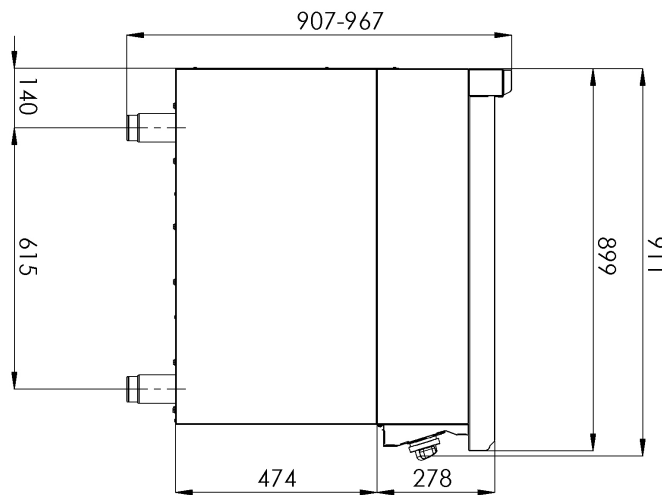
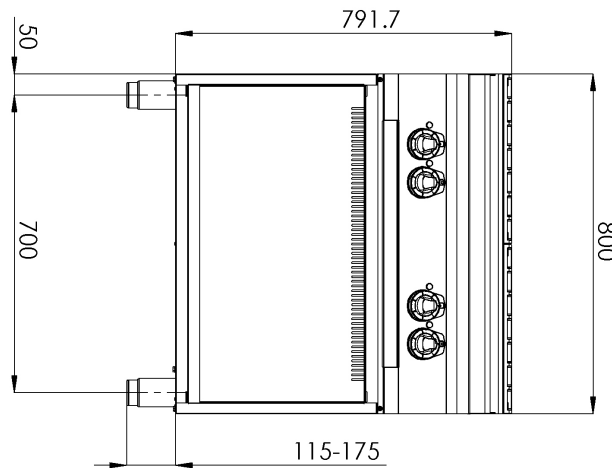

Cooking range electric 4x plate on open cabinet 400 V

Model	SAP Code	00012398
SPL 90/80 E	A group of articles - web	Stoves

1

Square plates

quick warm-up
efficient cooking on a large square surface

- time-saving in food preparation
- easy to use thanks to the large surface area of the cooking plates

2

Internal thermostatic plate protection

longer service life of the plates

- no overheating of the plates and no cracking

3

Degree of protection of the control elements IPX4

maintenance-free system
resistance to splash water
long life

- savings on service interventions
- easy cleaning and maintenance of equipment

4

All-stainless design

long life
resistance of a ground steel plate with a thickness of 10 mm

- savings on service interventions
- higher corrosion resistance

5

Hygienic moldings of the top plate

absence of sharp corners and edges (potential places where dirt could stick)
smooth transitions

- easy quick cleaning

6

Variability

the possibility of adding to the current line
easy possibility of creating one module
long life

- cost saving
- space saving
- long service life

Technical data sheet



Technical parameters

Cooking range electric 4x plate on open cabinet 400 V

Model	SAP Code	00012398
SPL 90/80 E	A group of articles - web	Stoves

1. SAP Code:

00012398

2. Net Width [mm]:

800

3. Net Depth [mm]:

900

4. Net Height [mm]:

900

5. Net Weight [kg]:

107.00

6. Gross Width [mm]:

840

7. Gross depth [mm]:

970

8. Gross Height [mm]:

1160

9. Gross Weight [kg]:

122.00

10. Device type:

Electric unit

11. Construction type of device:

With substructure

12. Power electric [kW]:

10.000

13. Loading:

400 V / 3N - 50 Hz

14. Material:

AISI 304 top plate, AISI 430 cladding

15. Worktop material:

AISI 304

16. Worktop Thickness [mm]:

1.50

17. Number of zones:

4

18. Power consumption of the zone 1 [kW]:

3

19. Power consumption of the zone 2 [kW]:

3

20. Power consumption of the zone 3 [kW]:

3

21. Power consumption of the zone 4 [kW]:

3

22. Number of power control stages:

7

23. Adjustable feet:

Yes

24. Number of burners/hot plates:

4

25. Diameter of device [mm]:

300

26. Type of electric cooking zones:

Squared

27. Cross-section of conductors CU [mm²]:

4